

SHIPPED COMPONENTS

- 1 table top with pivot leg assembly
- 2 foot assemblies

HARDWARE

- 2 hex bolts
- 2 spring washers
- 2 flat washers

WARNING: Protect top surface from scratches while attaching base feet.

TOOLS REQUIRED

- 1 socket driver, 1/2"

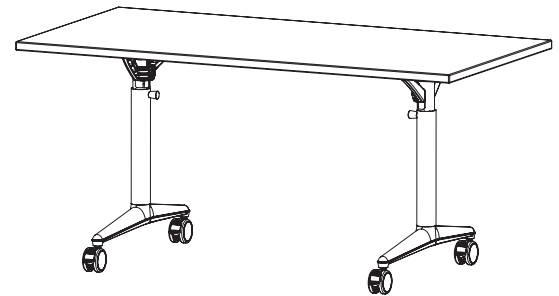

VECTA

flip top tables L- and T-base feet assembly instructions

akira™

A Steelcase Company

Design: Christian Corneilus

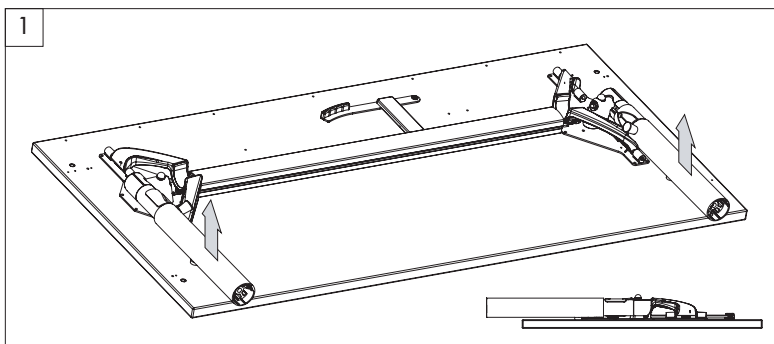

Carefully place the folded table on a clean carpeted surface. Rotate the legs to a vertical position by pulling the legs up and engaging the top support wings. A clicking noise indicates that the legs are locked and table unfolded.

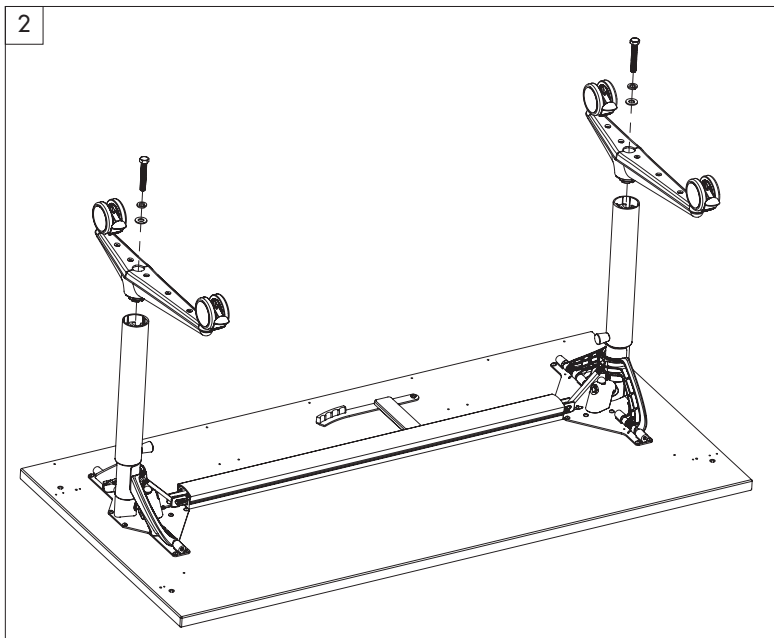
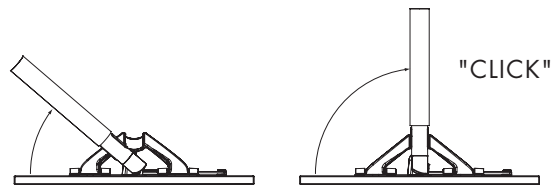

Align the feet assemblies over the lower legs. Place the spring washer followed by the flat washer on to the bolt. Place bolt with washers through the center hole in the foot and into the threaded plate. Tighten the bolt screw with 1/2" socket driver to 60 ft/lbs.

