

# AWAIT- GANGING INSTRUCTIONS

Aug. 16,2006

The Await seating group utilizes a 'lift-n-drop' style ganging system. The ganging plates are attached to the seating units using 1 1/2" Black Hex Head bolts. Listed below are the steps involved in attaching the ganging plates to a unit, and then connecting multiple units together.

**Step. 1** Per the room layout for the Await units, attach either a male, or female, ganging plate(s) to the bottom edge of the units in the designated hole locations. Refer to Figures 1A & 1B for attachment illustrations. (ex. 461-1B, 1-unit Bench)

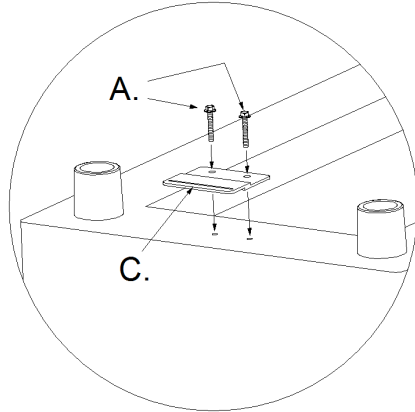

Fig. 1A, Female Plate Attachment

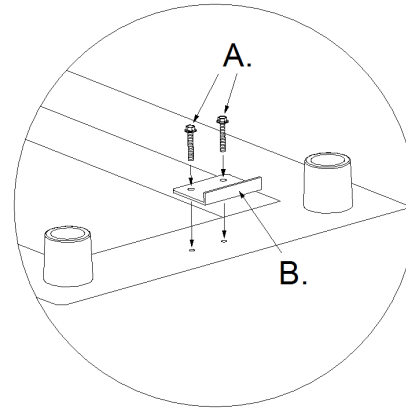

Fig. 1B, Male Plate Attachment

Ganging Items: A. #95374, 1/4-20 x 1 1/2" Serr. Hex. Head, Black bolt. B. #04039, Male Ganging Plate, Black. C. #04053, Female Ganging Plate, Black.

**Step. 2** Once all of the units have the needed ganging plates attached, return the units to their upright position. Lift the unit with the Male Ganging Plate(s) and carefully drop the lip of the male plate into the exposed groove of the Female Ganging Plate that is extended out from the bottom edge of the mating unit as illustrated in Fig. 1C. The ganging plates interlock as shown in the 'Bottom View' drawing of Fig. 1C.

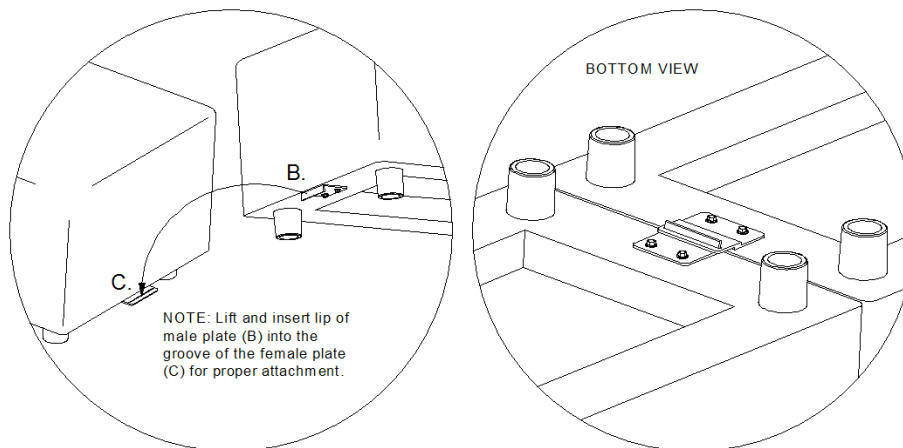

Fig. 1C

**NOTE:** The overall layout of ganged Await units in a room will determine which unit receives either a male, or female, ganging plate(s). Typically in a layout where several units are ganged together, every other unit will have either all males, or all females, ganging plates.

## AWAIT Connector Table Tablet Attachment and Ganging Plate Instructions

### Tablet Assembly Attachment:

Before ganging the Connector Table(s) to the Await seating units, first attach the Tablet Assembly to the Connector Table. If your unit does not require a Tablet Assembly, proceed to the 'Ganging Plate Attachment' section of the instructions.

**Step 1.** Carefully insert the rod of the Tablet Assembly into the hole located in the top surface of the Connector Table as shown below. Insert the tablet rod until it comes in contact with the bottom panel of the unit.

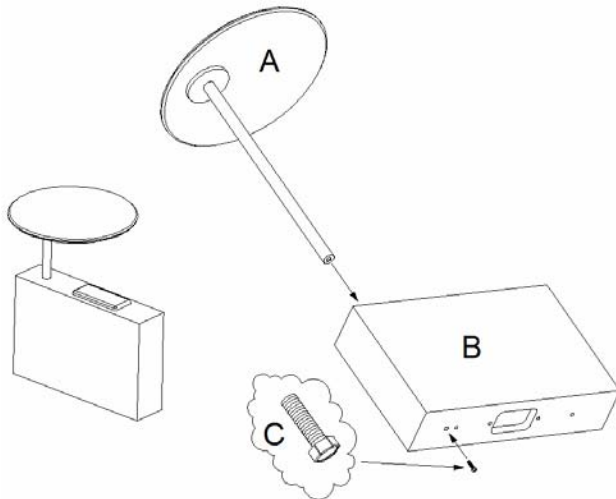

- A. Tablet Assembly
- B. Connector Table Unit
- C. 2" Tablet Rod Attachment Bolt

**Step 2.** Insert the supplied 3/8" dia. x 2" attachment bolt (C) through the hole in the bottom of the Connector Table and thread into the bottom of the tablet rod inserted in the previous step and tighten.

**NOTE:** Do not over tighten. This attachment bolts primary function is to vertically locate the tablet rod. Also if the tablet assembly needs to be removed at a later date, simply unscrew the attachment bolt and remove the Tablet Assembly.

Example: 460-SE22 w/Tablet & Power/Data Module

### Ganging Plate Attachment:

Before ganging the Connector Table(s) to the Await seating unit, you first must connect the ganging plates to the bottom side of the seating units. After the ganging plates are attached and the seating units are positioned accordingly, then the Connector Table can be attached.

**Step 3.** After determining the needed location and direction of the ganging plates, insert the supplied 1/4" dia. x 1 1/2" black attachment bolts (B) through the corresponding holes in the ganging plates (A) and into the holes in the black bottom of the seating units and tighten.

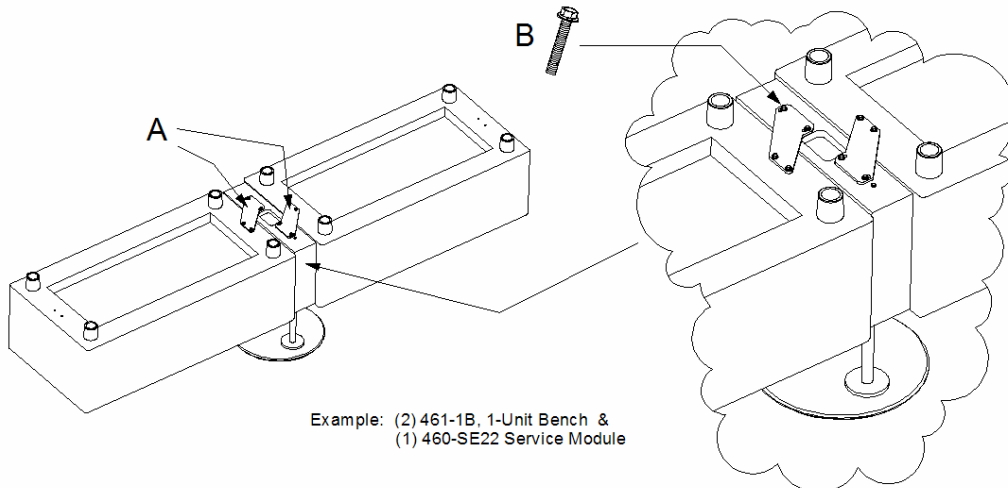

Example: (2) 461-1B, 1-Unit Bench &  
(1) 460-SE22 Service Module

**Step 4.** Once the ganging plates have been attached, roughly space the units 4 ½"-5" apart revealing the ganging plates at the bottom of the space between the seating unit.

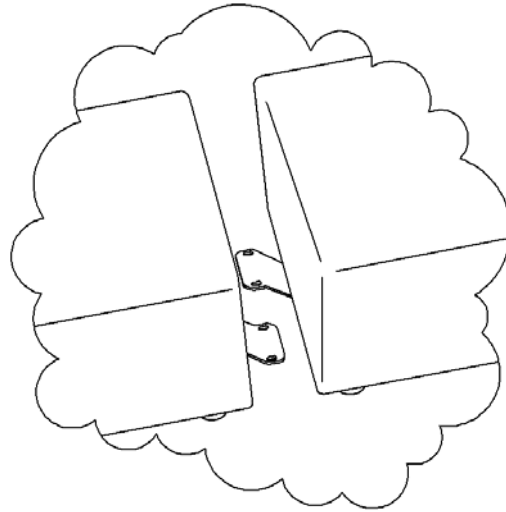

**Step 5.** Carefully slide the Connector Table down into the space until it comes to rest on the exposed ganging plates at the bottom.

**Step 6.** Using the black attachment bolts mentioned in Step 3, insert the bolts up from the floor, through the slotted holes in the ganging plates, and into the corresponding attachment holes in the bottom panel of the Connector Table and tighten.

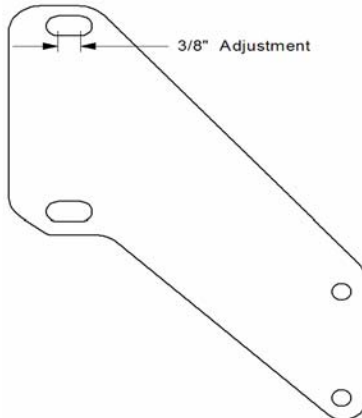

**Note:** The slotted attachment holes in the ganging plates offers 3/8" adjustment if needed for a snug fit between the sides of the Connector Table and the seating units. To achieve this snug fit, once the assembly is complete, loosen the bolts mentioned in Step 6, but do not remove them, relocate the mating seating units closer for a better fit and re-tighten the bolts.

