

ROUND 48"
Product Number 336942



SQUARE 42" x 42"
Product Number 431942



RACETRACK (8') 96" x 48"
Product Number 275947



Base: 3" diameter extruded aluminum column. Base foot is low profile, 4" wide aluminum with radiused edges. A cast aluminum toe pad, 5.5" long, semi-racetrack in shape, is attached to the base foot. Tables may be specified without the toe pad. Concealed, non-marring adjustable glides.

Base Finishes: Polished aluminum and Vecta powder coat colors. Column, base foot and toe pad may be in any combination of finishes.

Top Material: Plastic laminate or wood veneer.

Edge: Vinyl, self-edge, solid wood edge in the following shapes: convex, beveled, knife or waterfall. Edge options are determined by table top shape. Please refer to price list.

Shape: Round, square, rectangle, racetrack, boat, half-round, 90 degree arc, and wedge tops.

Grangers available.

Height: 29"

Flip Top: Flip top option offered on 30" and 36" round and square tables.

Design: Michael Walsh

©1993, 1995, 1996, 1999, 2001, 2006 Vecta®
A Steelcase® company.
Form number 19606, updated 8/06.

MODULAR TABLE CONFIGURATION
THREE RECTANGLES (6') 72" x 30"
Product Number each table 474946
TWO CONNECTING TOPS 45° x 30"
Product Number each top 381000D



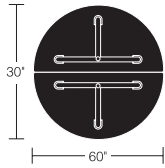

Two half round tops
Seating Capacity - 6
2 ganger kits provided with each half round
Note: Half round tops are not for independent use

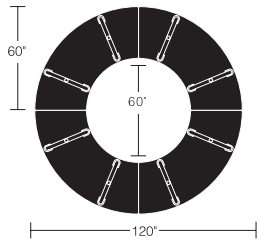

Four 90° arc connecting tops
Seating capacity - 12
2 ganger kits provided with each 90° arc

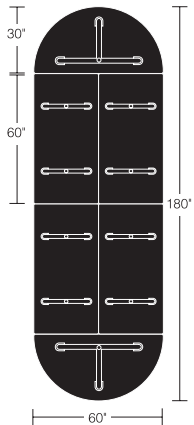

Two half round tops
Four 60" x 30" rectangles
seating capacity - 14
2 ganger kits provided with each half round top
Order 4 additional ganger kits

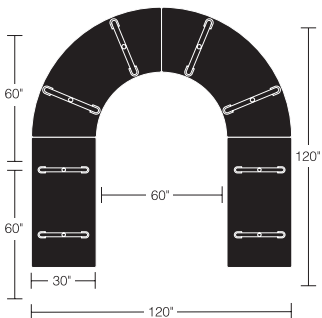

Two 90° arc connecting tops
Two 60" x 30" rectangles
Seating Capacity - 10
2 ganger kits provided with each 90° arc

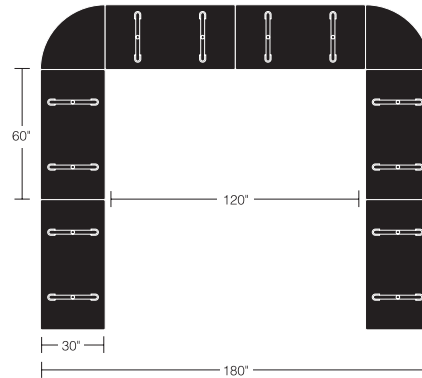

Six rectangles 60" x 30"
Two 90° wedge connecting tops
Seating capacity - 14
2 ganger kits provided with each wedge connecting top
Order three additional ganger kits

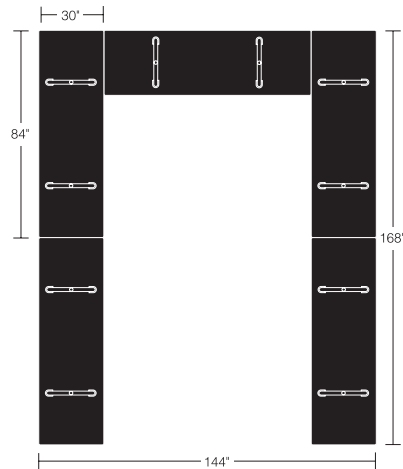

Five rectangles 84" x 30"
Seating capacity - 14
Order four ganger kits

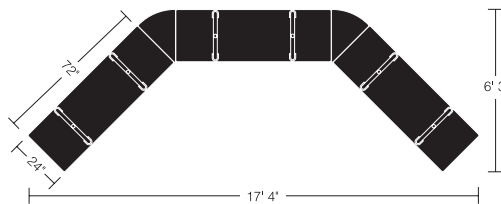

Three rectangles - 72" x 24"
Two 45° wedge connecting tops
Seating capacity - 8
Two ganger kits provided with each 45° wedge connecting top

Derby tables may be joined together to create modular conference, training or seminar configurations.

Base: 3" diameter extruded aluminum column. Base foot is low profile, 4" wide aluminum with radiused edges. A cast aluminum toe pad, 5.5" long, semi-racetrack in shape, is attached to the base foot. Tables may be specified without the toe pad. Concealed, non-marring glides.

Base Finishes: Polished aluminum, Vecta powder coat colors. Column, base foot and toe pad may be in any combination of finishes.

Top Material: Plastic laminate or wood veneer. Please refer to Vecta price list for essential information when specifying wood veneer tables that are to be ganged or are to be used in the same location.

Edge: Vinyl, self-edge, solid wood edge in the following shapes: convex, beveled, knife or waterfall. Flat vinyl edge is recommended when tables are to be ganged. Edge options are determined by table top shape. Please refer to price list.

Gangers available.

Shape: Round, square, rectangle, racetrack, boat, half-rounds, 90 degree arcs, wedge tops.

Height: 29"

Design: Michael Walsh

©1993, 1995, 1996, 2004, 2006 Vecta®
A Steelcase company.
Form number 19607, updated 7/04